



### ***Table of Contents***

<u>Section</u>	<u>Page</u>
Principle of Operation	2
Applications	4
Features	7
Options / Accessories	8
Ordering Information	14
Technical Data	15

## Principle of Operation

### Introduction

The BlueLevel Technologies Model RH/RHX is a heavy duty automatic level control instrument. It is used to detect the presence/absence of powders and granular materials at predetermined levels within bins, hoppers, silos and other types of vessels. The Model RH/RHX operates efficiently within a wide array of industrial settings such as food, plastic processing, grain, feed, biofuel, seed, chemical, concrete, cement and many others. The universal nature of these level control instruments in bulk solids applications is because of their heavy duty and rugged nature, as well as their time proven operating principle.

### Use

The Model RH/RHX can be used for high (full detection), low (empty detection) and intermediate (demand detection) level monitoring, as well as plugged chute detection, applications. These instruments operate based on a proven principle dating back to the mid-1930's. Time proven, enhanced over the decades, the rotary paddle bin level indicator remains the most universally applied automatic level control for powders and bulk solids.

### Function

Units are equipped with a heavy duty synchronous drive motor [1] housed in a rugged die-cast aluminum enclosure [2]. The drive motor [1] is connected to the paddle by way of a stainless steel output shaft [3] that is structurally supported by four shielded bearing assemblies [4] to ensure a long life and smooth operation in the harshest of environments.

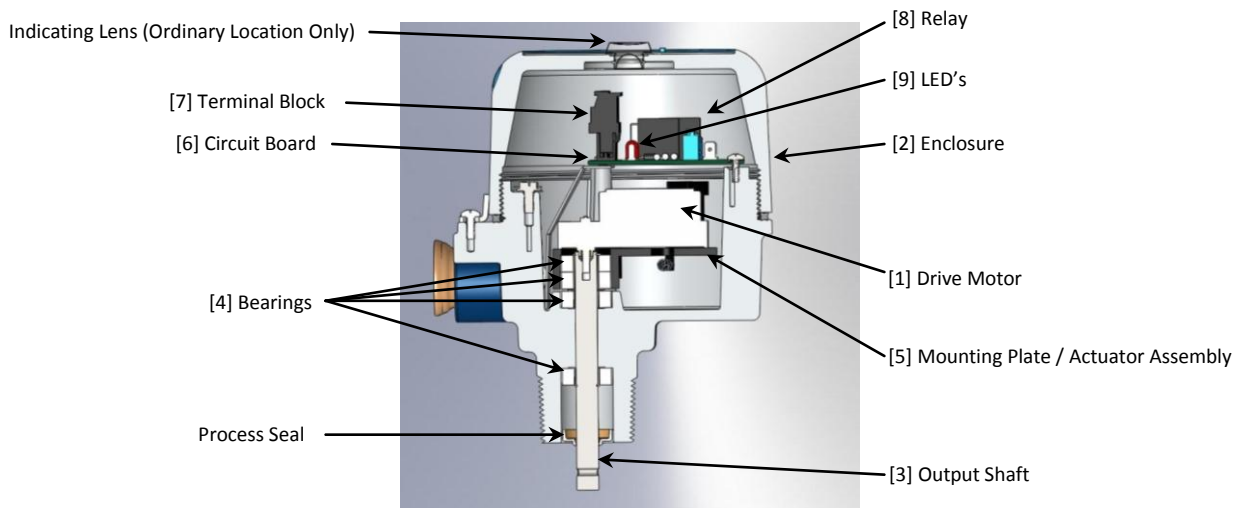

The unit's drive motor [1] is mounted within the enclosure on a spring-loaded mounting plate [5] with attached switch actuator. A circuit board [6] containing user terminal block connections [7], output relay [8] and high intensity LED indicators [9] is mounted above the drive motor assembly.

During normal operation, with no material present at the paddle, the Model RH/RHX drive motor [1] turns the paddle at 1 RPM freely within the bin that the unit is mounted on. When the material being monitored reaches the rotating paddle, the rotation is impeded by the material. The drive motor will pivot on its spring-loaded mounting plate [5] and the switch actuator will engage the output switch on the circuit board [6], which de-energizes the electromechanical relay [8] and changes the state of the relay contacts indicating material presence. In addition, this switch will change the state of the high intensity LED's [9]. The motor mounting plate will continue to rotate within the enclosure until the actuator activates a second switch on the circuit board that disconnects power to the drive motor.

As the material in the bin recedes away from the paddle, the drive motor will pivot back towards its original position. This will restore power to the drive motor and reverse the state of the relay output and LED indication.

---

#### Standard Fail-Safe Alarm Output

Model RH/RHX bin level indicators are equipped with a “fail-safe” switch that allows the alarm condition to exist whenever the power supply to the unit fails. In a low level control application the alarm state occurs (de-energized relay) when the material is ABSENT. In the high level control position the “fail-safe” switch will cause the alarm condition to occur (de-energized relay) when material is PRESENT. The LED's follow the alarm condition, Red indicates that an alarm condition exists and Blue indicates that a normal condition exists.

---

## Applications

### General

High, low and intermediate level indication and plugged chute detection are common applications within a wide variety of industries. In addition, these units can be provided for use in top or side mounting installations with or without mounting plates. BlueLevel Technologies provides White Papers, Podcasts, Video and other Media about the use and considerations when selection level measurement and monitoring instrumentation at our website [www.blueleveltechnologies.com](http://www.blueleveltechnologies.com)

Mounting of Model RH/RHX units can be from side or top of bins, including at oblique angles. Top mounted units can be provided with extension shafts and guards for up to 12ft (3.6m) in length (guards must be used when the extension length exceeds 24" (610mm)).

### Top Mounted (High/Full Detection)

Top mounted applications are for monitoring high level (full) conditions. These applications use a Model RH/RHX power pack with flexible coupling, extension shaft, guard (for >24"/610mm lengths), full-coupling mounting plate and paddle. See assembly view below.

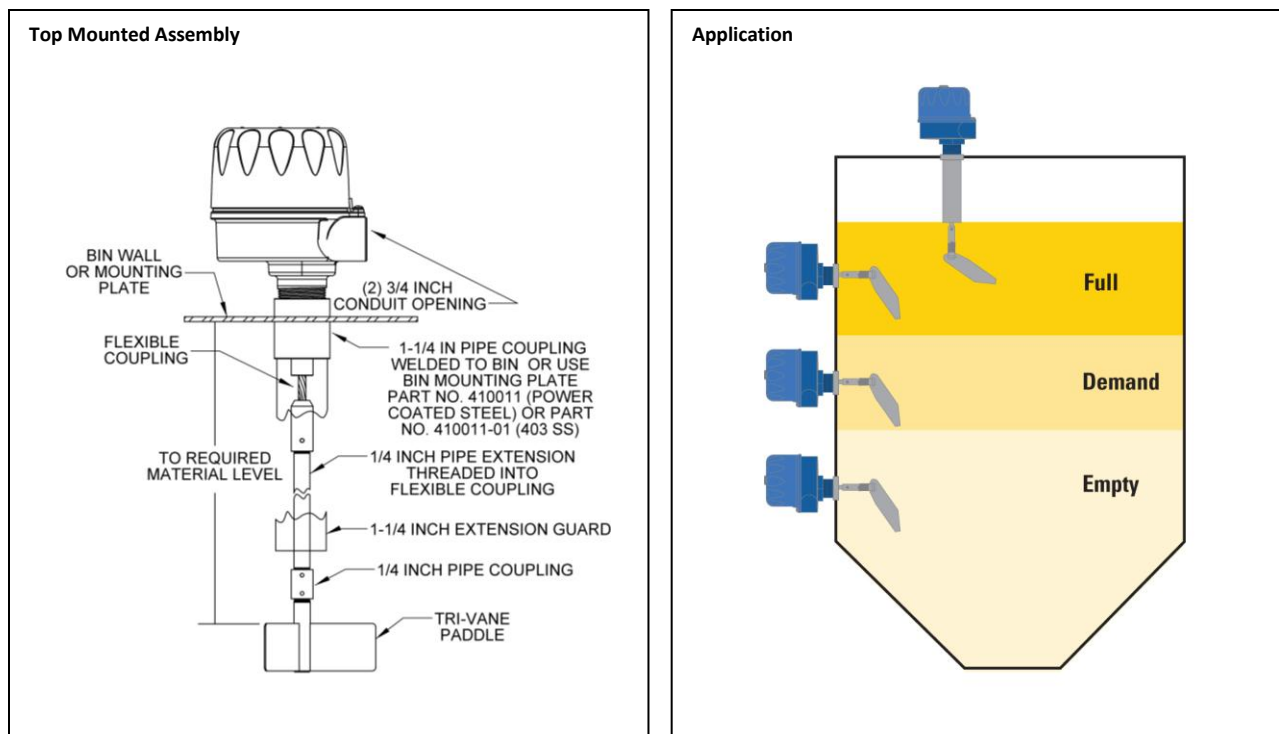

Side Mounted

Side mounted installations can be used for monitoring high (full), intermediate (demand) or low (empty) level conditions. These can be accomplished using standard Insertable paddles, folding Insertable paddles and regular paddles requiring internal installation or use of a half-coupling mounting plate for insertion from outside the bin.

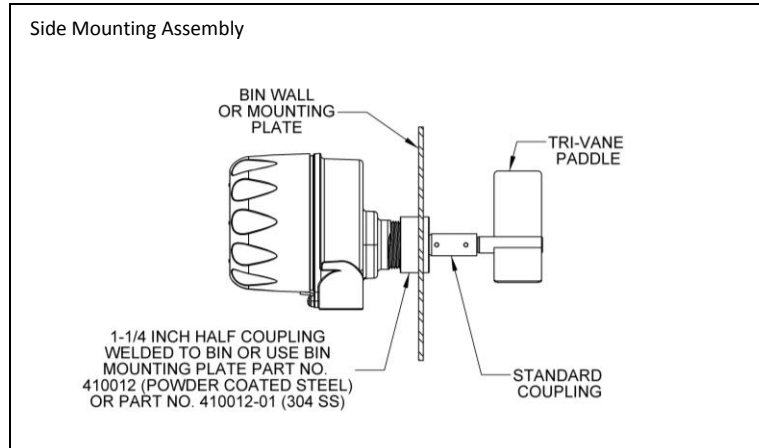

Materials

Typical powder and bulk solid materials that can be monitored using the Model RH/RHX rotary paddle bin level indicators include materials with density from 5lbs/ft<sup>3</sup> (80kg/m<sup>3</sup>) for low (empty) and intermediate (demand) level control applications and from 10lbs/ft<sup>3</sup> (160kg/m<sup>3</sup>) for high (full) level indication and control. A wide variety of paddles are available (refer to Options/Accessories section) to fit the application based on Function (high/intermediate/low), Bulk Density and Installation Method. Example materials that can be monitored with the Model RH and RHX include:

Plastic Pellet	Food Ingredients	Feed
Grains	Cement	Nuts
Flour	Resins	Aggregates
Sand	Coal	Chemicals
Limestone	Wood	Sawdust

**Installation**

BlueLevel Technologies Model RH and RHX can be mounted in a variety of installations, including top and side mounting as previously discussed. In addition, the Model RHX can be installed in Hazardous Locations according to electrical code and safety standards for Class I and II areas. Refer to the Technical Data section for specific details.

The Model RH and RHX are easily adaptable to replace other brands. By choosing one of the available couplings you can use the paddles from your previous brand, such as <sup>1</sup>Bindicator®, Monitor, <sup>3</sup>BinMaster® and others.

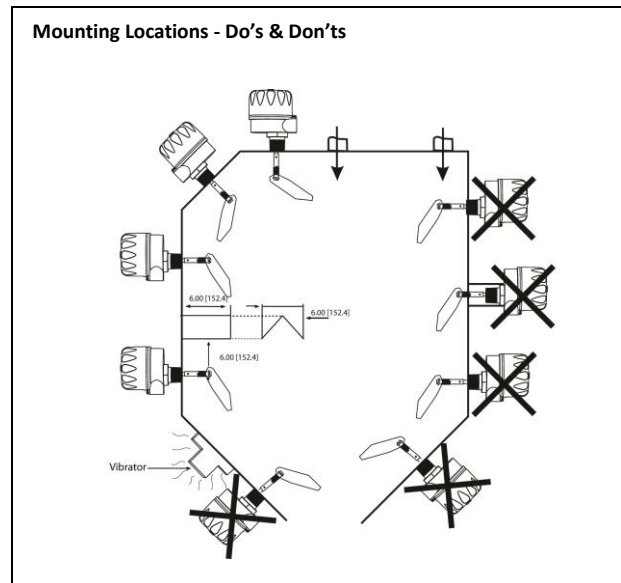
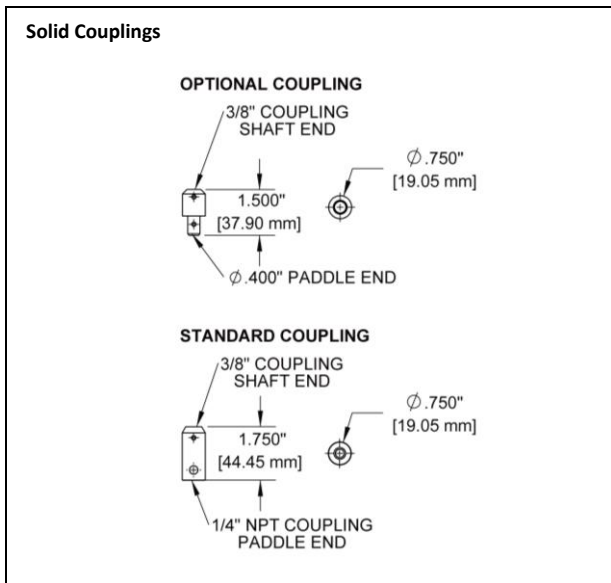

Refer to the Installation, Operation and Maintenance Instruction document supplied with the Model RH/RHX for specific details and safety precautions.

<sup>1</sup> Bin-dicator is a registered trademark of Venture Measurement

<sup>3</sup> BinMaster is a registered trademark of Garner Industries, Inc.

---

## Features

A wide range of Features make the Model RH and RHX the best choice for most all of your level detection applications for powders and granular materials. The following is a list of primary features common to all units, unless otherwise noted.

- ✚ All Model RH units include a Blue and Red high intensity LED and an impact-resistant lens for local visual indication of Alarm status.
  - ✚ Four shielded bearing design ensures long life and responsive trouble-free operation.
  - ✚ Heavy-duty synchronous drive motor equipped with built-in clutch, along with the sensor' automatic motor shut-off extends motor life in all applications.
  - ✚ Choice of paddle couplings allows for easy replacement of other brands by using your existing paddles.
  - ✚ Use of food grade materials provides compatibility with food and agriculture applications. Includes use of FDA compliant powder coating, NSF listed anti-seize for cover threads, stainless steel shaft, paddles and accessories, and an FDA compliant process seal.
  - ✚ Fail-Safe DPDT relay output is switch selectable for either High or Low. This protects your process against conditions that might arise from power failure to the unit.
  - ✚ Choice of 24VAC, 115VAC, 230VAC 50/60Hz and 12VDC, 24VDC operation provides a flexible choice for your specific power arrangement.
  - ✚ Model RHX units include an explosionproof enclosure and are suitable for use in Hazardous Locations.
  - ✚ Two ¾" NPT conduit entrances improve wiring access.
  - ✚ High temperature version handles process temperatures up to 750°F (399°C).
-

## Options/Accessories

BlueLevel Technologies offers a variety of options and accessories for the Model RH and RHX rotary paddle bin level indicators. These include Couplings, Extensions, Mounting Plates and Paddles.

### High Temperature Option

The Model RH/RHX is available in two process temperature versions to handle a wide range of applications. The high temperature version incorporates all the standard features and benefits of the standard temperature version, but can be used in applications where the process temperature may reach as high as 750°F (399°C). The high temperature version incorporates a specially designed mounting plate, pipe extension with air purge connection, shaft extension and bushings. The high temp unit is available in stainless steel construction for the extension pieces, mounting plate, seal and paddle. It can be ordered without shaft coupling for use with the BlueLevel Technologies folding Insertable paddles or with either the Standard or Optional paddle coupling.



### Hazardous Location Option

The Model RHX is the rotary paddle bin level indicator version certified conforming to CSA and UL standards for use in hazardous vapor and dust locations. This version does not include the visible LED indicators external of the unit, while the LED's are resident on the circuit board inside the unit. The Model RHX is certified for Class I, Div. 1 & 2, Groups C & D, and Class II, Div. 1 & 2, Groups E, F and G.

### Couplings

Two solid couplings are available. These are the Standard and Optional paddle couplings. When ordered as part of the Model RH/RHX they are secured to the output shaft of the unit.

The **Standard Coupling** (PN 410013) is used to attach paddles from BlueLevel Technologies, BinMaster and Monitor Technologies. The Standard Coupling uses a threaded female connection on the paddle end of the coupling and a female receptacle for the output shaft of the level control power pack on the other end (refer to drawing at right). The paddle threads into the Standard Coupling and a secure attachment is made with the roll pin supplied with the BlueLevel Technologies paddle.

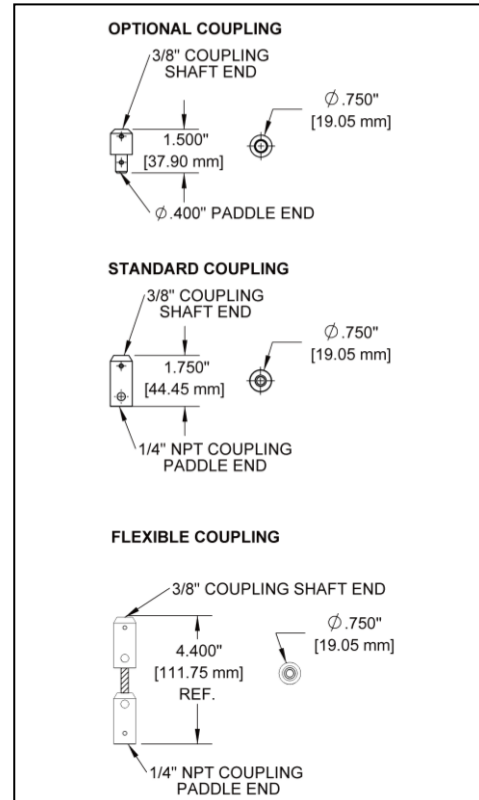



The available **Optional Coupling** (PN 410014) is used to adapt most paddles from Bindicator, Conveyor Components Company and K-Tek Corporation. This coupling provides a male connector for attaching the paddles and a female receptacle for the units' output shaft. The paddle is secured to the coupling using the roll pin supplied with the BlueLevel Technologies paddle.

A **Flexible Coupling** (PN 410002) is available, which replaces the Standard Coupling, and provides a flexible connection for the paddle to the output shaft of the Model RH/RHX unit. When using a Flexible Coupling, order the Model RH/RHX unit without a coupling. Then, attach the Flexible Coupling accessory item to the units' output shaft using the roll pin supplied with the Flexible Coupling.

### Paddles

A variety of paddles are available to meet the vast majority of applications considering different material densities, particle sizes and flow characteristics.

#### *2-Vane Folding Paddle:* (PN 410003)

Insertable from outside the bin through the 1¼" process connection. This paddle can eliminate the cost of a solid Standard Coupling. The surface area and 7¾" rotation diameter allows this paddle to be used effectively for detecting the presence of materials with approximate bulk densities of 20-80lbs/ft<sup>3</sup> (320-1280kg/m<sup>3</sup>). 304 stainless steel construction. CAN BE USED FOR SIDE AND TOP MOUNTING.

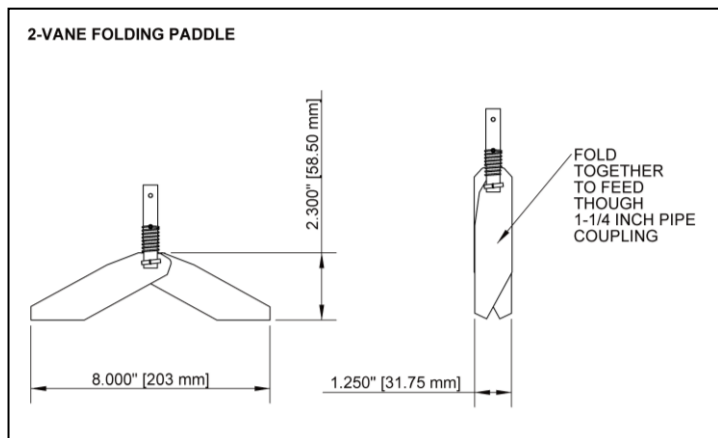

#### *1-Vane Folding Paddle:* (PN 410004)

Insertable from outside the bin through the 1¼" process connection. This paddle can eliminate the cost of a solid Standard Coupling. The surface area is half that of the 2-Vane Folding Paddle but with the same 7¾" rotation diameter. This paddle can be used for materials with bulk densities of approximately 40-80lbs/ft<sup>3</sup> (640-1280kg/m<sup>3</sup>). 304 stainless steel construction. CAN BE USED FOR SIDE AND TOP MOUNTING.

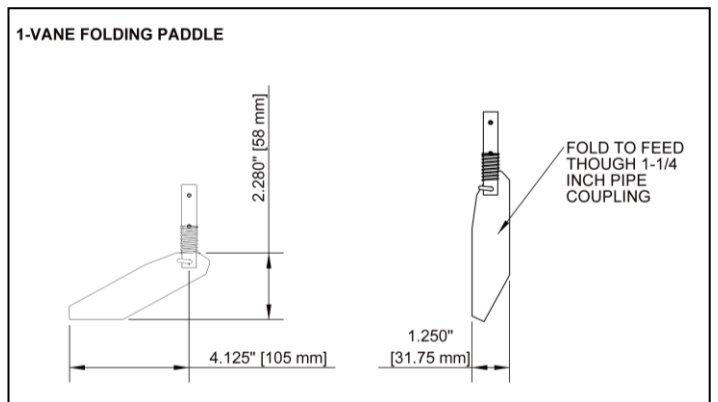

**Standard Tri-Vane Paddle:** (PN 410000) 3-Vane paddle rotates in 5" diameter. This paddle requires the use of the solid Standard Coupling or Flexible Coupling for attachment. It is installed from inside the bin or from outside with the use of a Mounting Plate accessory. This paddle can be used for detecting materials with bulk densities of approximately 30-70lbs/ft<sup>3</sup> (480-1120kg/m<sup>3</sup>). 304 stainless steel construction.

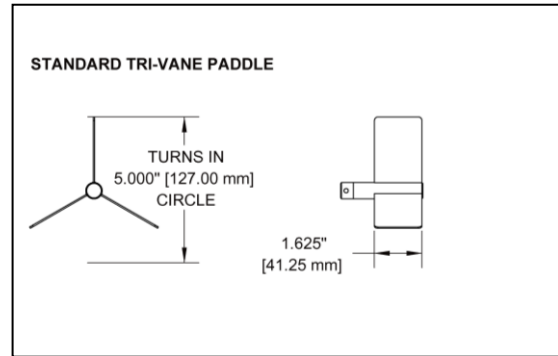

**Large Tri-Vane Paddle:** (PN 410001) 3-Vane paddle rotates in 7" diameter. This paddle requires the use of the solid Standard Coupling or Flexible Coupling for attachment. It is installed from inside the bin or from outside with the use of a Mounting Plate accessory. This paddle incorporates larger vanes than the Standard Tri-Vane and is typically used for detecting lighter weight materials with bulk densities up to 30lbs/ft<sup>3</sup> (480kg/m<sup>3</sup>). 304 stainless steel construction.

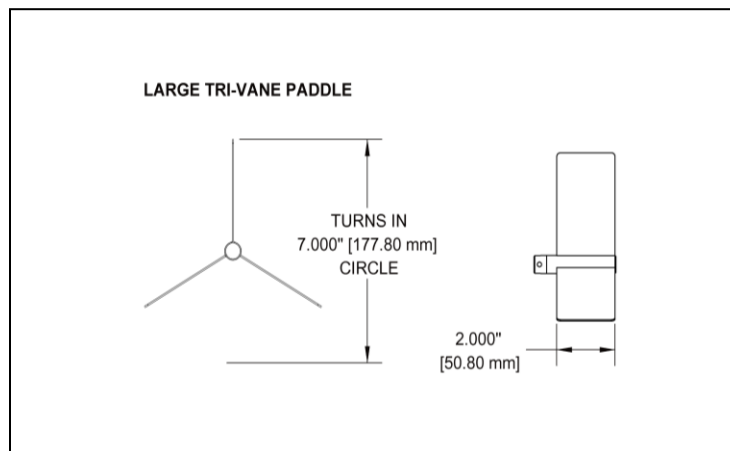

**Insertable "Banana" Style Paddle:** (PN 410015) Single-vane "banana" style paddle is Insertable from outside of the bin. This paddle requires the use of the solid Standard Coupling or Flexible Coupling. The "banana" paddle turns in a 6¾" diameter rotation. The surface area and rotation diameter allow this paddle to be used to detect materials with bulk densities of approximately 30-70lbs/ft<sup>3</sup> (480-1120kg/m<sup>3</sup>). 304 stainless steel construction.

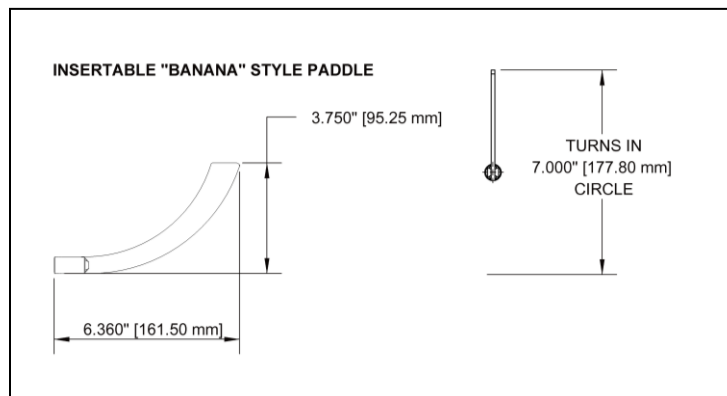

**Heavy-Duty 1-Vane Insertable Paddle:** (PN 410016) The Heavy Duty insertable 1-vane paddle incorporates an 1/8" thick stainless steel paddle blade and is used for detecting the presence of bulk materials with densities  $\geq 50\text{lbs/ft}^3$  ( $800\text{kg/m}^3$ ). This paddle requires the use of the solid Standard Coupling or Flexible Coupling for attachment. 304 stainless steel construction.

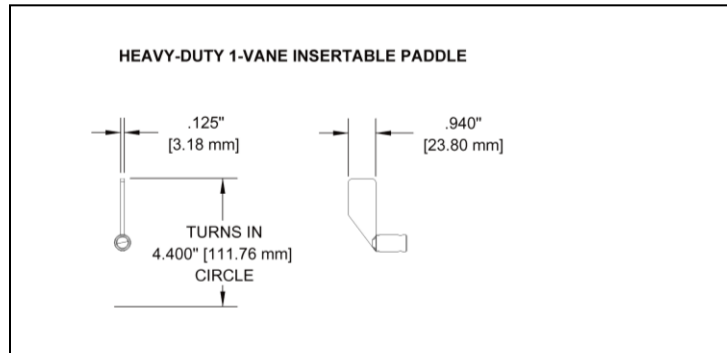

**Heavy-Duty 2-Vane Paddle:** (PN 410019) The Heavy Duty 2-vane paddle incorporates an 1/8" thick stainless steel paddle blade and is used for detecting the presence of bulk materials with densities  $\geq 45\text{lbs/ft}^3$  ( $800\text{kg/m}^3$ ). This paddle requires the use of the solid Standard Coupling or Flexible Coupling for attachment. 304 stainless steel construction.

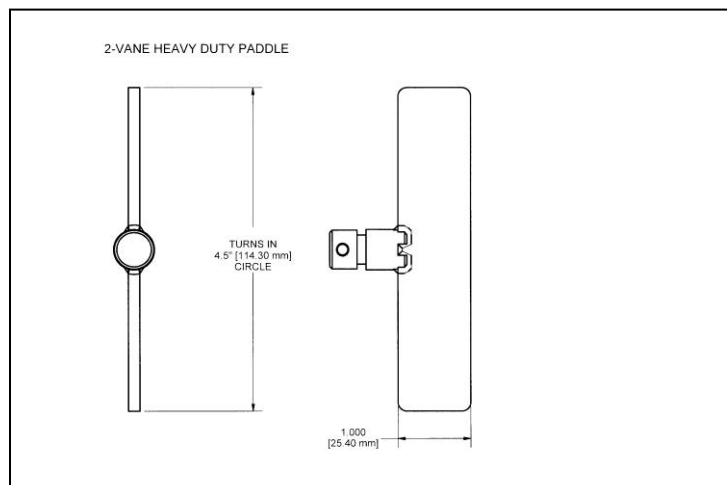

**Heavy-Duty 4-Vane Paddle:** (PN 410020) The Heavy Duty 4-vane paddle incorporates an 1/8" thick stainless steel paddle blade and is used for detecting the presence of bulk materials with densities  $\geq 45\text{lbs/ft}^3$  ( $800\text{kg/m}^3$ ). This paddle requires the use of the solid Standard Coupling or Flexible Coupling for attachment. 304 stainless steel construction.

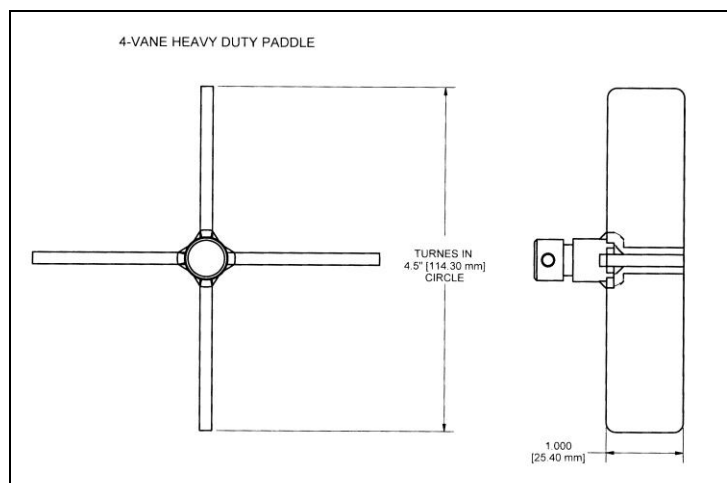

**Mounting Plates**

Half and Full Coupling Mounting Plates are available for use to install the Model RH/RHX assembly from outside the bin when using a paddle, such as the Standard and Large Tri-Vane paddles, that cannot be inserted from outside the bin. Both Half and Full Coupling Mounting Plates are available in powder coated carbon steel or 304 stainless steel materials.

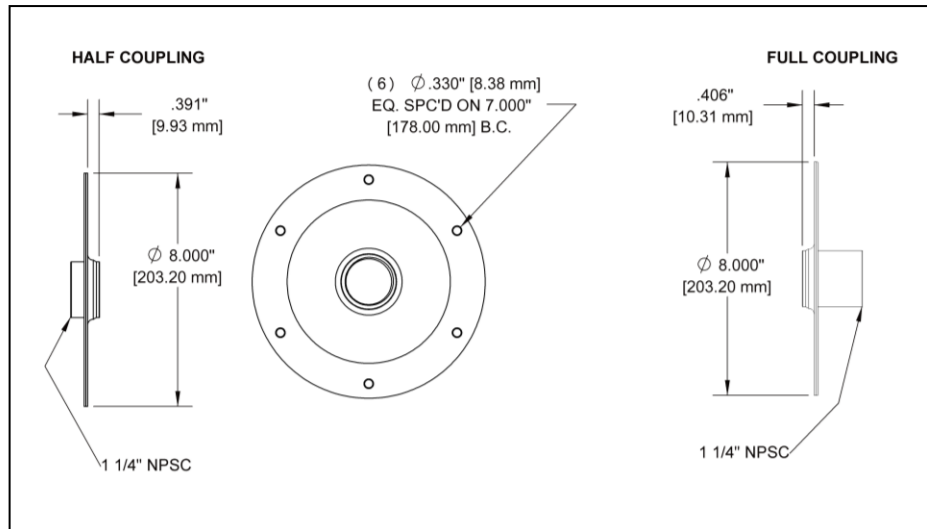

Half Coupling Mounting Plates are typically used for side mounting applications.

Full Coupling Mounting Plates are used for top mounting applications where an extension guard is used and is threaded into the underside of the Mounting Plate.

- Half-Coupling Powder Coated Steel - PN 410012
- Half-Coupling 304 Stainless Steel - PN 410012-01
- Full-Coupling Powder Coated Steel - PN 410011
- Full-Coupling 304 Stainless Steel - PN 410011-01

**Shaft Extensions / Guards**

High level detection applications that are mounted on top of the bin require the sensing paddle to extend into the bin to the predetermined level for proper monitoring and control. Solid Shaft Extensions are available in galvanized or 304 stainless steel material and can be used to extend the paddle reach up to 144" (3.6m). Extension lengths > 20" (510mm) requires the use of an extension shaft Guard. Guards are available in galvanized or 304 stainless steel. Shaft Extensions and Guards are cut to the specific length for the application.

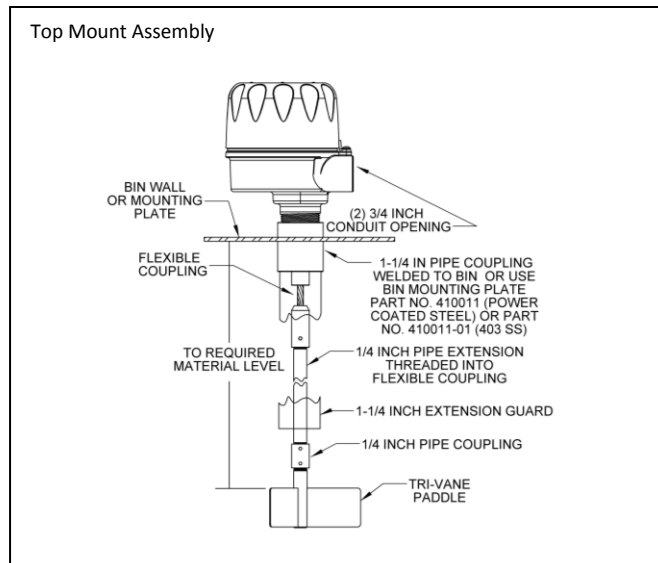



A Flexible Coupling should be used to attach the Extension Shafts to the Model RH/RHX unit as shown in the above drawing. When ordering Extensions and Guards the customer specified length must be included.

Galvanized Shaft Extension - PN 410007

Stainless Steel Shaft Extension - PN 410008

Galvanized Shaft Guard - PN 410009

Stainless Steel Shaft Guard - PN 410010

---

## Ordering Information

Model RH/RHX Rotary Paddle Bin Level Indicator

Part Number Structure

4 0 - 1 X X X - 1 X X

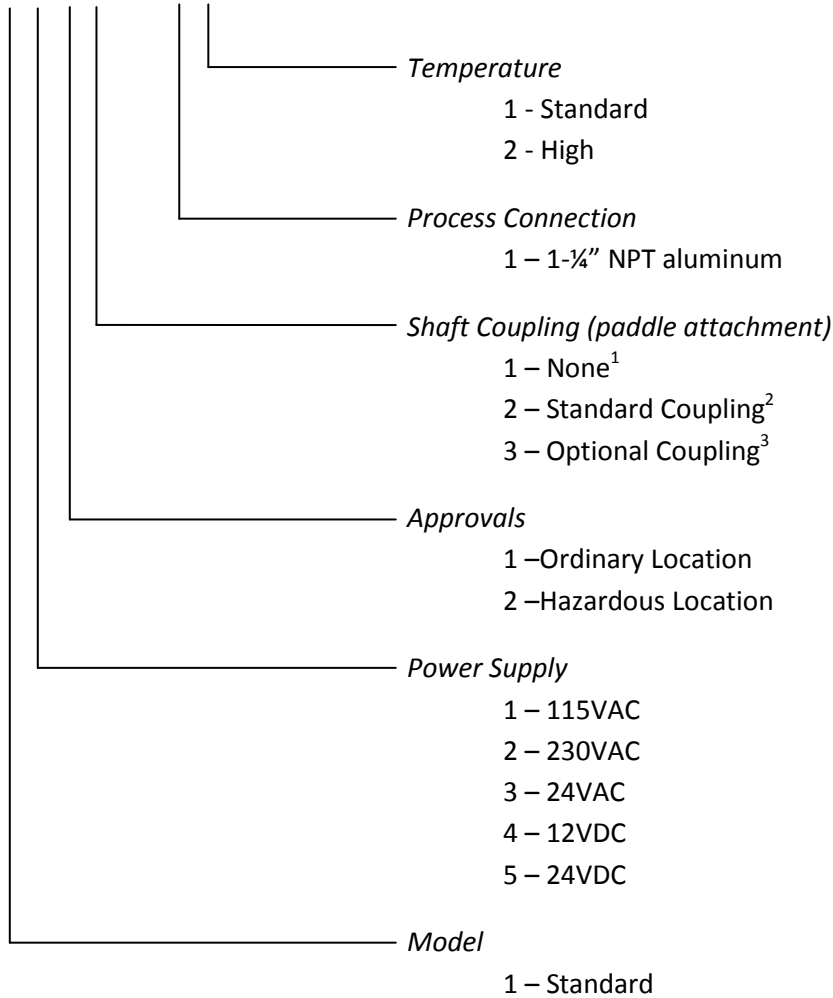

<sup>1</sup> Use with BlueLevel, and most BinMaster brand folding paddles.

<sup>2</sup> Use with BlueLevel, and most BinMaster and Monitor brand paddles. Comes assembled to output shaft when ordered with the unit.

<sup>3</sup> Use with Bindicator, and most KTek and Conveyor Components brand paddles. Comes assembled to output shaft when ordered with the unit.

## Technical Data

Power Supply:	24VAC, 115VAC or 230VAC; 50/60Hz; 12VDC or 24VDC
Supply Tolerance:	+10%/-15%
Power Consumption:	5.5VA, 1W
Ambient Temperature:	-40°F to +158°F (-40°C to +70°C) -40°F to +140°F (-40°C to +60°C)
Process Temperature:	
Standard	Up to +300°F (+149°C)
High Temp	Up to +750°F (+ 399°C)
Enclosure:	NEMA 4X, IP65, Die-Cast Aluminum with FDA Compliant Powder Coat
Output:	DPDT Relay, 8A @ 250VAC, Fail-Safe on Power Failure
Fail-Safe Selection:	Switch Selectable, High or Low
Process Connection:	1¼" NPT
Conduit Entry:	Two (2) ¾" NPT
Bearings:	Four (4) Sealed Bearings
Shaft Seal:	½ Micron, 30psi (2bar)
Materials of Construction:	
Enclosure	Powder Coated Die-Cast Aluminum
Output Shaft	304 SS
Couplings/Paddles	304 SS
Shaft Seal	304 SS w/ FDA Compliant FKM
Mounting Plates	Powder Coated Carbon Steel or 304 SS
Extension Shafts/Guards	Galvanized or 304 SS
Weight	3.65lbs (1.65kg)

Certifications (Certified to UL, CSA and EU Standards):

Model RH  
Model RHX

CE Mark, <sub>c</sub>LC<sub>us</sub> Ordinary Locations

<sub>c</sub>LC<sub>us</sub>: Class I, Div. 1 & 2, Groups C and D

<sub>c</sub>LC<sub>us</sub>: Class II, Div. 1 & 2, Groups E, F and G

Dimensions

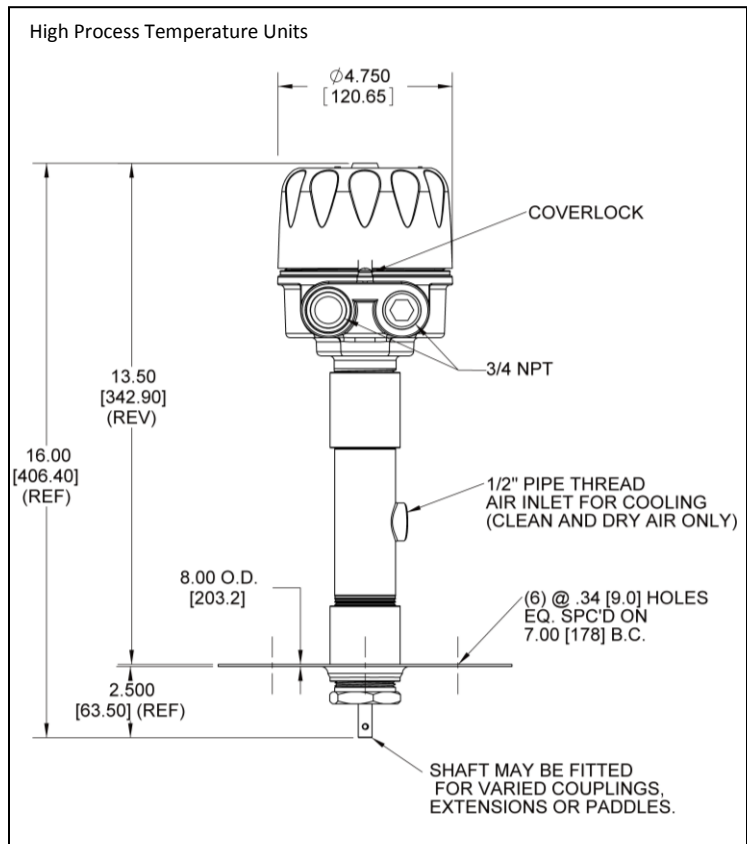
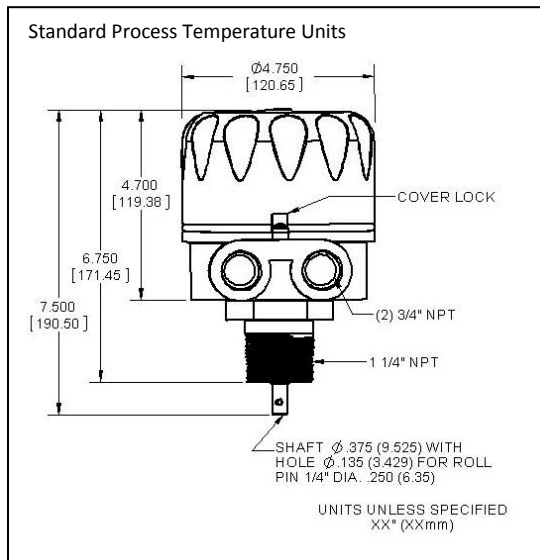





BlueLevel Technologies, Inc.  
3778 Timberlake Drive, Richfield, OH 44286  
Ph: 330-523-5215 | Fx: 330-523-5212

[bluelevel@blueleveltechnologies.com](mailto:bluelevel@blueleveltechnologies.com) • [www.blueleveltechnologies.com](http://www.blueleveltechnologies.com)  
Skype: BluelevelTech Also on Facebook, Twitter and LinkedIn